

American Traction Systems

2000HP Locomotive Diesel Electric Propulsion System



April 2010

American Traction Systems
10030 Amberwood Road
Fort Myers, Florida 33913

Voice: +1 (239) 768-0757

<http://www.AmericanTraction.com>

American Traction Systems

Description of System - Main components of the Traction System

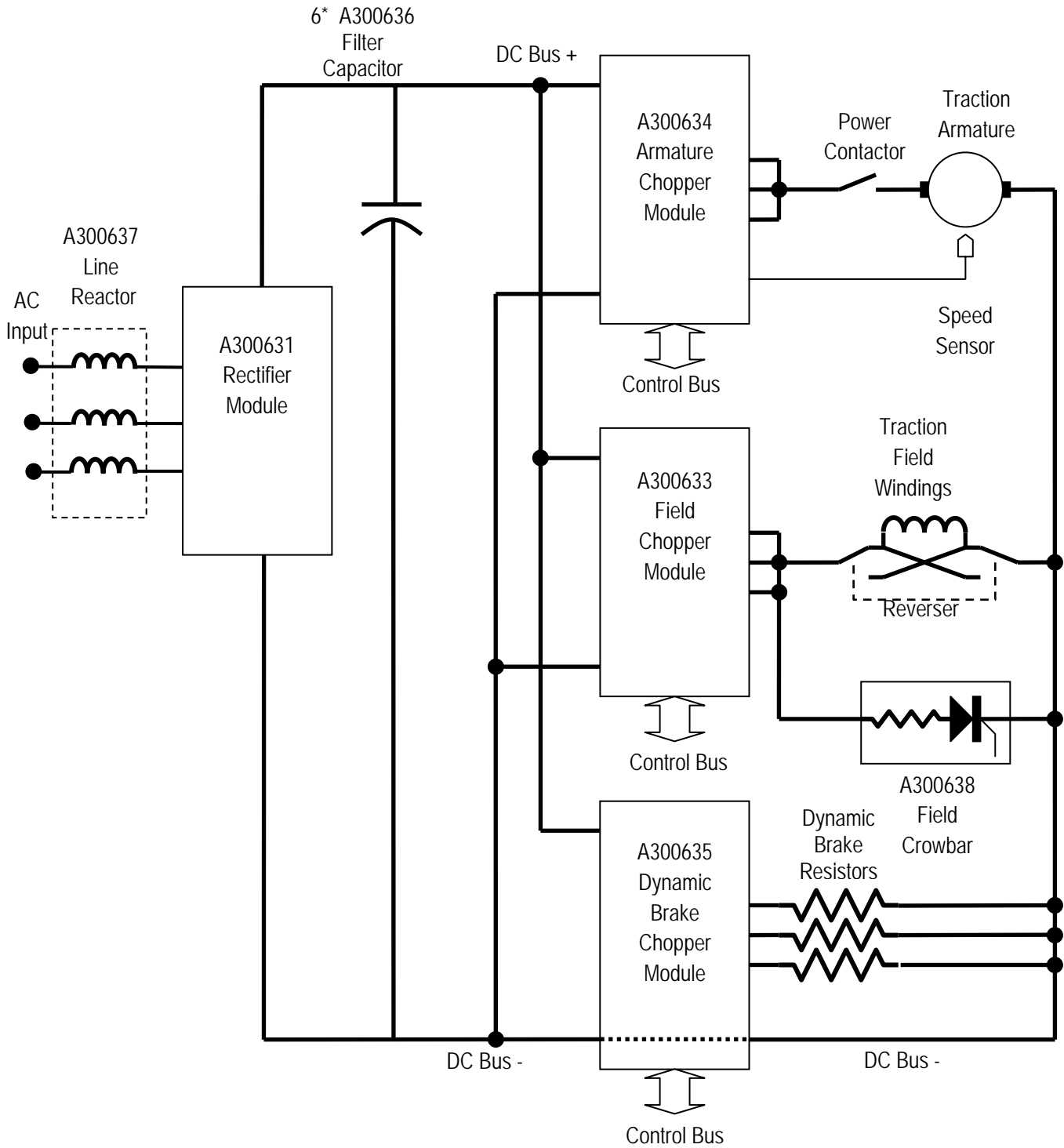

Description of Modules

The A300631 Rectifier Module converts 480V, 60Hz AC power to DC power at a voltage of approximately 650V. The output of the rectifier module is smoothed by six A300636 parallel-connected capacitors. Line reactor, A300637, reduces the harmonic load on the 480V supply. The A300631 rectifier module consists of a half-controlled SCR / Diode bridge for the purpose of limiting the charging current drawn by the bus capacitors during power up.

The A300633, A300634 and A300635 Chopper Modules are power converters designed to operate over a DC bus voltage range of 500V to 800V. They are used as components of a power conversion system consisting of several modules sharing a common DC bus filter capacitor.

When the A300634 Armature Chopper Module is used to control the armature of a DC traction motor, it controls the armature current by applying pulses of the DC bus voltage directly to the armature at a frequency of 1kHz. The pulse width, or duty cycle, is varied from zero to a full 1ms period in accordance with the voltage required by the armature. This requirement is determined by a high-speed current regulator which continuously seeks to maintain the output current at a level that matches the value of the traction reference. The mean current drawn from the DC bus is proportional to the duty cycle as well as the armature current. This means that the chopper can supply the armature with a very large amount of current at low speed while consuming a relatively small amount of current from the DC bus. The Armature Chopper Module also receives speed feedback from the axle that it is driving and continuously compares the measured axle speed with a reference input derived from a non-driven axle. For the purpose of controlling wheel-spin or wheel-slide, a speed regulator overrides the traction reference with a lower value if the axle speed deviates outside a small band of acceptable values.

The Armature Chopper Module can also operate very effectively as a brake down to very low speeds. It achieves this by applying a voltage to the armature that is lower than its open-circuit voltage so that both current and power flow are reversed. This change occurs as a seamless transition when the polarity of the traction reference is reversed.

Energy recovered from the traction motors during dynamic braking is returned to the DC bus. All of the energy returned to the bus must be dissipated without resulting in a large increase in voltage. The excess power is absorbed in dynamic brake resistors controlled by the A300635 Dynamic Brake Chopper. The Dynamic Brake Chopper normally operates independently by responding only to the increase in DC bus voltage that occurs when power absorbed by the Armature Chopper Modules is returned to the DC bus. A self-load mode is provided for the purpose of applying a test load to the traction power system while the car is stationary.

The A300633 Field Chopper Module has identical construction and is used to control the current in the motor field. Typically, a locomotive has either 4 or 6 identical traction motors. The fields require very little voltage, consequently, they may be connected as a series string controlled by a single chopper. By commanding the field current to be equal to the armature currents, the overall traction capability can be made to follow characteristics similar to those of the conventional series-field arrangement. At the nominal DC bus voltage of 750V, traction motors of the EMD D77 and D78 series with typical gearing have a base speed equivalent to approximately 25mph. Above this speed, the field current must be progressively weakened in order to extend the speed range. A spill-over field control system is implemented by using the armature controllers to send a field weakening request when any one of them reaches a duty cycle of 100%.

A separately-excited motor operating at high speed with a weak field can produce a very high armature voltage if the field controller fails in such a way that the DC bus voltage is applied directly to the field circuit. The A300638 Field Crowbar is used to prevent a high armature voltage arising in the event of a failure to a high field condition. On detection of such a condition, the SCR in the Field Crowbar diverts the field controller output through a low-value resistor in order to blow the fuse in the Field Chopper Module.

Environmental Specifications

Installation

Modules are designed for installation in a dry, dust-free environment maintained within a temperature range of -20°C to +50°C.

Each module contributes approximately 120W of thermal load to the ambient air. Sufficient space or ventilation must be provided for this heat to be dissipated without causing the ambient temperature to exceed the upper limit of +50°C.

The modules must be positioned so as to eliminate the possibility of any spilled fluid entering the module when coolant hoses are disconnected.

The modules should be isolated from sources of vibration that would cause it to undergo prolonged exposure to levels greater than +/-1g or short periods of exposure to levels greater than +/-3g.

Storage

The module must be stored within a temperature range of -40°C to +85°C in a non-condensing environment. Plug the coolant connections to prevent escape of residual coolant.

American Traction Systems

Dimensions

Rectifier (A300631)

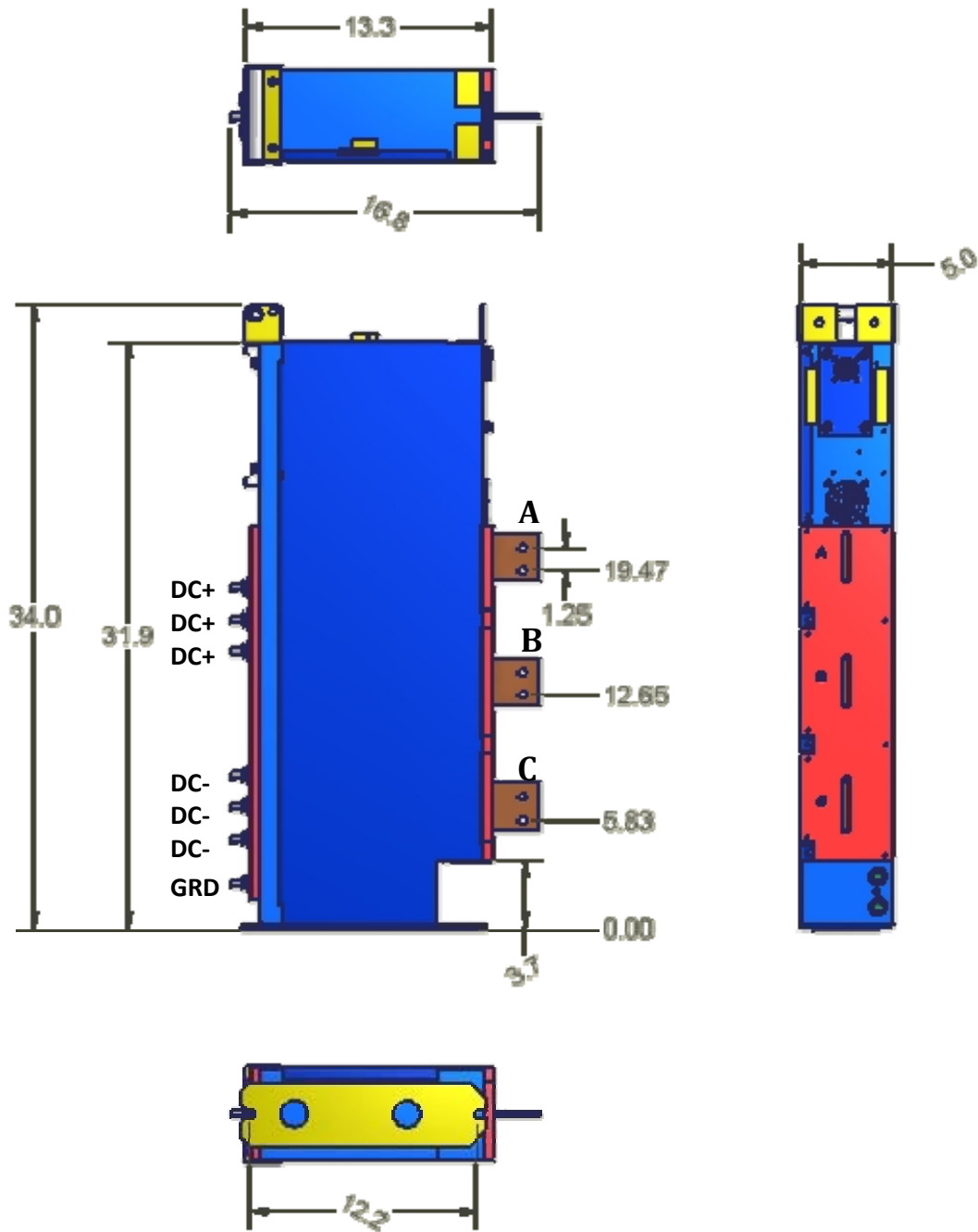

American Traction Systems

Field Chopper (A300633) Armature Chopper (A300634) and Brake Chopper (A300635)

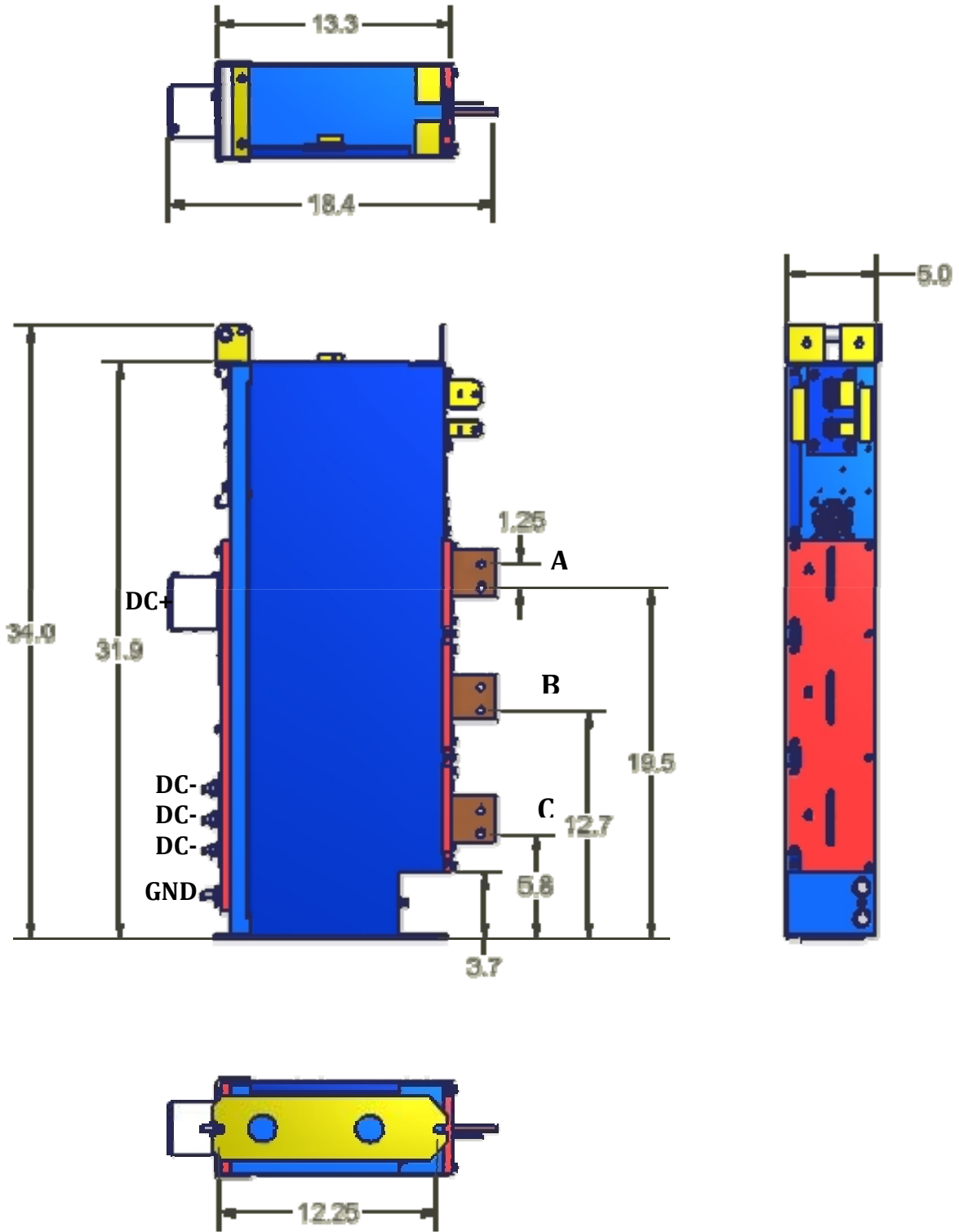

American Traction Systems

Figure 1: Typical System

***Drawing subject to change.

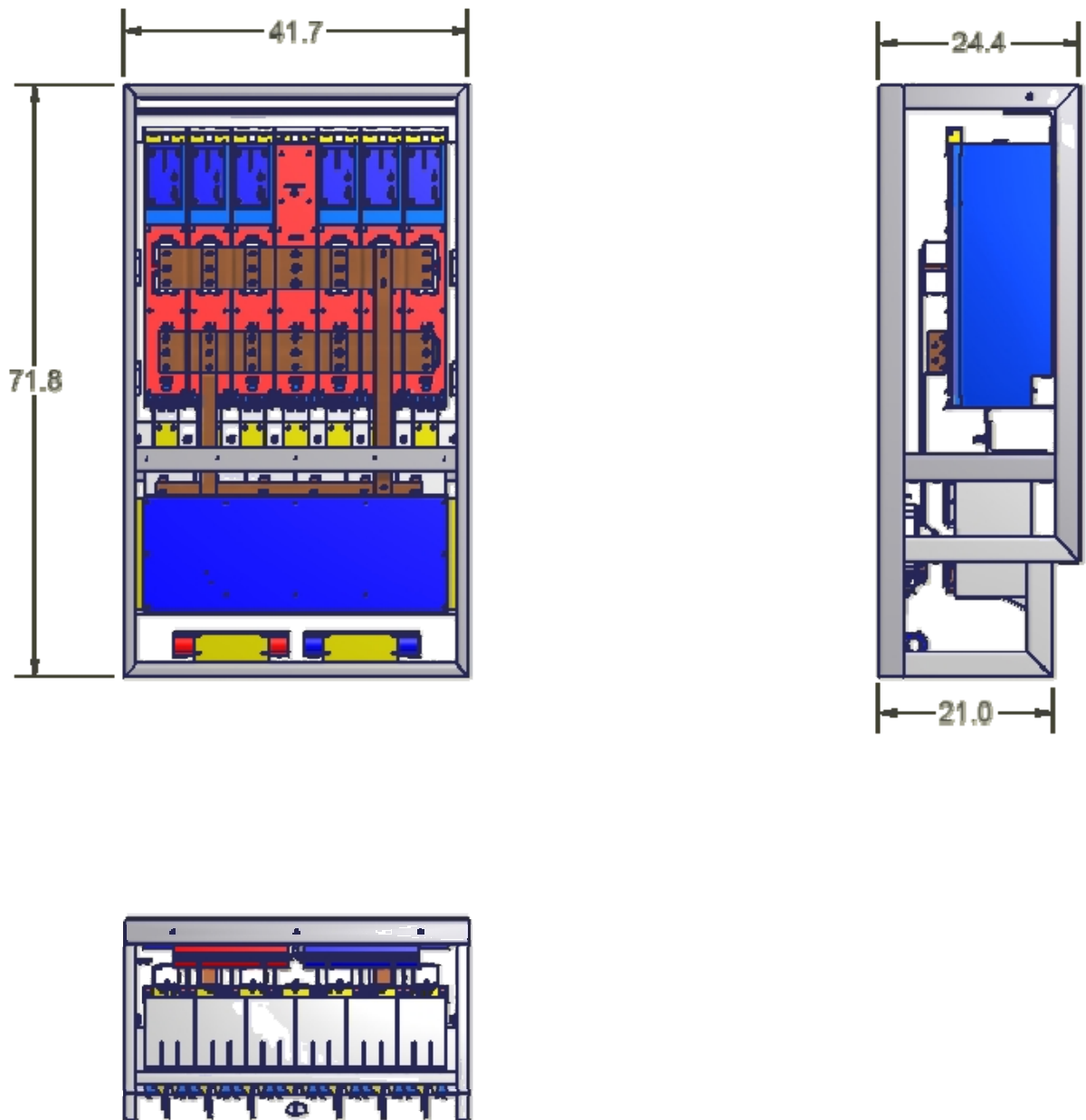

Specifications

Table 1: Specifications of the Armature Chopper Module (A300634)

DC Bus Voltage – Normal	500..800VDC
Input Current Continuous	1000A DC
Output Voltage	0..Input Voltage
Continuous Output Current	1000A DC
Short-time Output Current	1500A DC
Ambient Operating Temperature Range	-20°C..60°C
Coolant Temperature Range	-40°C..70°C
Control Supply Voltage	22..28VDC
Control Supply Current	1.5A DC
Minimum Coolant Flow	3 gal/min (11.25 l/min)
Maximum Coolant Pressure	50 psig (3.5 bar)

Table 2: Specifications of the Field Chopper Module (A300633)

DC Bus Voltage – Normal	500..800VDC
Input Current Continuous	500A DC
Output Voltage	0..Input Voltage
Continuous Output Current	1000A DC
Short-time Output Current	1500A DC
Ambient Operating Temperature Range	-20°C..60°C
Coolant Temperature Range	-40°C..70°C
Control Supply Voltage	22..28VDC
Control Supply Current	1.5A DC
Minimum Coolant Flow	3 gal/min (11.25 l/min)
Maximum Coolant Pressure	50 psig (3.5 bar)

Table 3: Specifications of the Dynamic Brake Chopper (A300635)

DC Bus Voltage – Normal	500..800VDC
Input Current Continuous	2000A DC
Output Voltage	0..Input Voltage
Continuous Output Current	3 x 666A DC
Ambient Operating Temperature Range	-20°C..60°C
Coolant Temperature Range	-40°C..70°C
Control Supply Voltage	22..28VDC
Control Supply Current	1.5A DC
Minimum Coolant Flow	3 gal/min (11.25 l/min)
Maximum Coolant Pressure	50 psig (3.5 bar)

Heatsink Losses (A300633 AND A300634)

Under conditions of zero output current, the heatsink losses are zero.

When output current is present, the heatsink losses are strongly dependent on the level of output current as shown in **Error! Reference source not found..**

Note that current is not equal in all modules during operation and the total losses in the system must be evaluated appropriately.

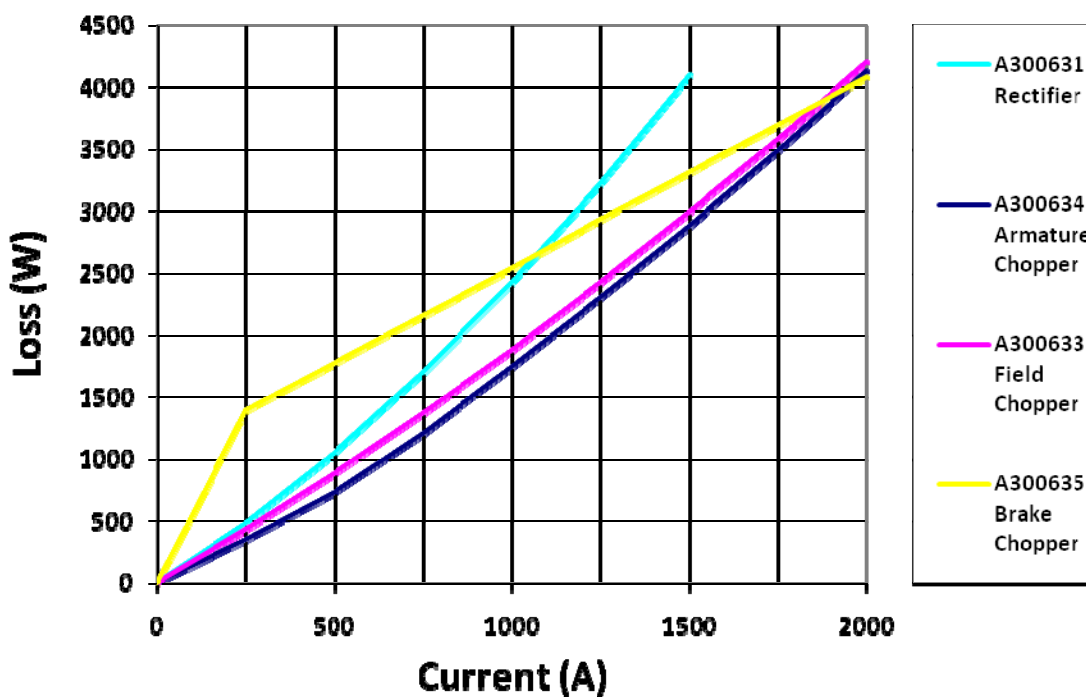

Heatsink Losses

Electrical Connections

Power Connections

Typical Power Connections for Traction Armatures

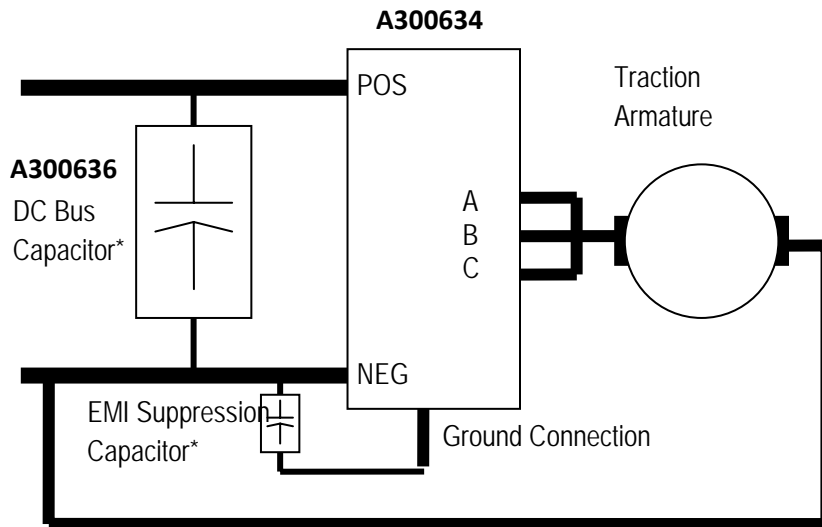

* Components shared by several modules

Typical Power Connections for the Traction Field

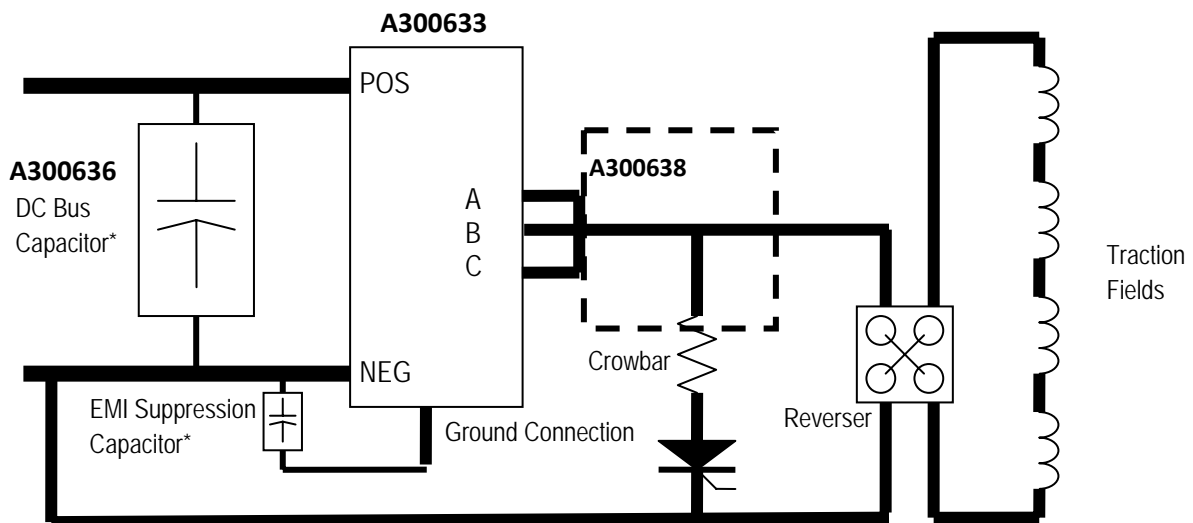

* Components shared by several modules

American Traction Systems

Typical Power Connections for the Dynamic Brake Grid

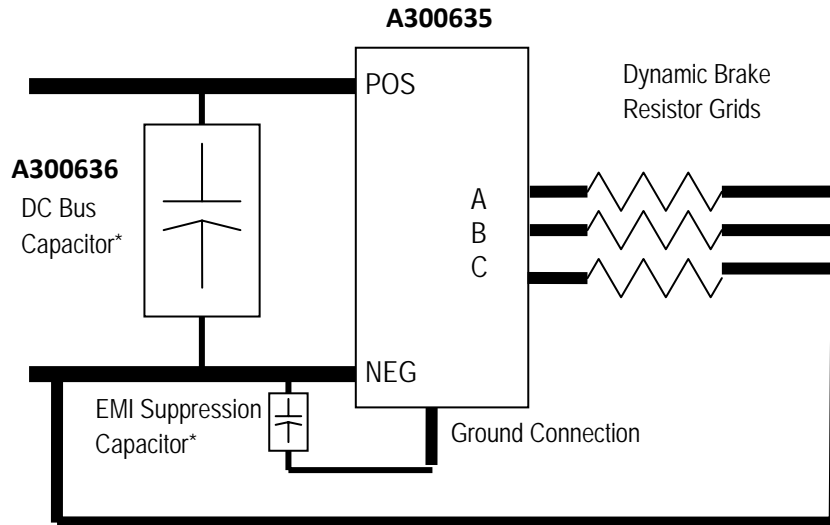

* Components shared by several modules

Typical Power Connections for the Rectifier

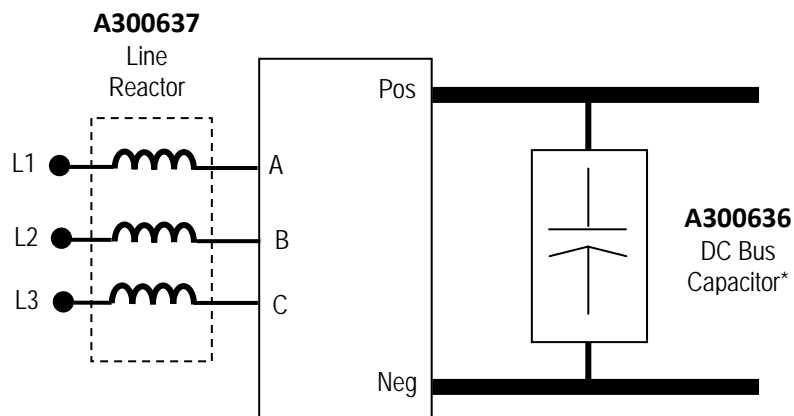

* Components shared by several modules

American Traction Systems

Electric Propulsion Controls and Accessories

For Technical Support Contact

American Traction Systems
10030 Amberwood Road
Fort Myers
Florida 33913

Voice: +1 (239) 768-0757
Fax: +1 (239) 561-0274

<http://www.AmericanTraction.com>